

# AQUILA 2

Girami frutteto frontale doppio - Front double pruning rake  
 Andaineur double à l'avant - Zweiseitiger kehrbesen

Martinetto per sfilo telescopico  
 Telescopic hydraulic jack  
 Vérin pour extension télescopique  
 Teleskopischer Hydraulikheber



Martinetto apertura braccio  
 Jack for lateral side arm  
 Vérin d'ouverture de bras  
 Jack für seitlichen Seitenarm



Martinetto alzata verticale braccio  
 Jack for vertical lifting arm  
 Vérin de levage vertical de bras  
 Jack für den vertikalen Hebearm

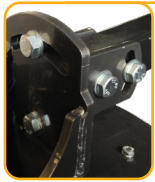

Campana girami con regolazione meccanica  
 Pruning rake kit with mechanical adjustment  
 Cloche de ramification d'arbre à réglage mécanique  
 Baumverzweigungsglocke mit mechanischer Einstellung

Gomma raduna tralci  
 Rubber collecting rakes  
 Râteaux ramasseurs en caoutchouc  
 Gummisammelharken

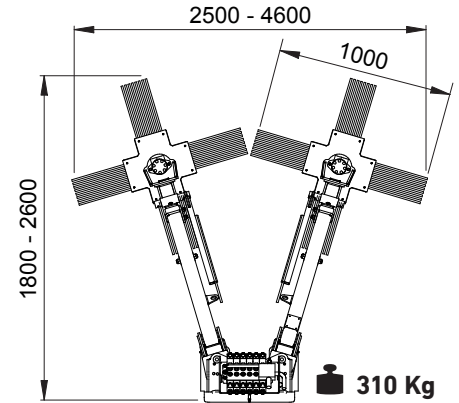

COD.	Movimenti - Movements - Mouvements - Bewegungen	Joystick	Distributore	Oil - Pressure
103700L	4+1  + ON/OFF MOTOR			30 lt/min 180 bar max
103710J	4+1  + ON/OFF MOTOR			30 lt/min 180 bar max
103711J	6+1  + ON/OFF MOTOR			30 lt/min 180 bar max

OPTIONAL	Descrizione - Description - Description - Beschreibung	
1A04810S	Radiatore - Oil cooler Refroidisseur - Kühler	
1A0350300	Valvola ripartitrice di olio per trattori oltre 50 lt/min. - Oil flow valve regulator for tractor over 50 lt/min. Régulateur d'huile pour tracteurs de plus de 50 l / min. - Ölverteilungsventil für Traktoren über 50 l / min.	
1A48000	Serbatoio posteriore indipendente con radiatore, pompa Gr.2 e 60 lt. olio - Independent oil tank with oil cooler, pump Gr.2 and 60 lt. of oil Réservoir arrière indépendant avec refroidisseur, pompe Gr.2 et 60 lt. d'huile - Unabhängiger hinterer Tank mit Kühler, Pumpe Gr. 2 und 60 lt. Öl	
1A32040	Piastra attacco rapido femmina - Female quickly connection Plaque d'accouplement rapide femelle - Weibliche Schnellkupplungsplatte	
1A32051	Staffa fissa maschio grezza - Male quickly connection Support fixe mâle - Rohe männliche feste Halterung	
1A32050	Staffa fissa al trattore (fornire modello e tipo di trattore) - Male connection for tractor (type and version of tractor) Support fixé au tracteur (indiquez le modèle et le type de tracteur) - Am Traktor befestigte Halterung (Modell und Typ des Traktors angeben)	
1A32060	Attacco a tre punti fisso - Fix three point linkage Attelage trois points fixe - Dreipunktaufhängung behoben	
1A32070	Attacco a tre punti con aggancio rapido per sollevatore - Three point attachment with quick coupling for lift Attelage trois points avec connexion pour relevage à l'avant - Dreipunktaufhängung mit Schnellkupplung für Lifter	